

Type 2 - Surge Protective Device (SPD)

Installation Instructions

Please read the following before installing your Rayvoss Transient Voltage Surge Suppression System:

- Verify the system voltage and configuration on the label is appropriate for the application.
- Risk of Electric Shock – Installation and maintenance should be performed by qualified personnel only.
- Disconnect from energized circuits before installing or servicing.
- Installation should conform to all applicable national and local codes.
- This product has a NEMA 4 rating. To maintain this rating, appropriately rated fittings must be used for installation.
- The maximum size conductor allowed in this product is #6 AWG.
- This unit should be installed behind a maximum 50A rated fused disconnect or circuit breaker when installed In-Line. For Parallel installations the unit may be installed behind larger overcurrent protective devices per Article 240.21 of the 2008 NEC.
- The enclosure door must be closed and secured prior to applying power to the unit.

Product Specifications

Nominal Voltage.....	120/240V Split Phase
Maximum Continuous Operating Voltage (MCOV) (L-G).....	150V
Nominal Discharge Current I_n (8/20 μ s) per UL 1449 3rd Edition (L-G, N-G).....	20kA
Voltage Protection Rating (VPR), in-line, per UL 1449 3rd Edition (L-G, N-G).....	500V
Voltage Protection Rating (VPR), in-line, per UL 1449 3rd Edition (L-N, L-L).....	1000V
Maximum Surge Current I_{max} (8/20 μ s) NEMA LS-1 (L-G, N-G).....	140kA
Maximum Lightning Current I_{imp} (10/350 μ s) IEC 61643-1 (L-G, N-G).....	7.5kA
Let Through Voltage Level for surge current 10kA (8/20) (L-G, N-G).....	435V
Long Duration Surge Performance 500A square waveform 2ms IEEE C62.11.....	250 hits
Response Time.....	< 1ns
Operating Temperature.....	-40...+85°C
Environmental Protection.....	NEMA 4 - Ip65
Enclosure Dimensions.....	12" x 12" x 8 1/2"

This product is Listed to UL 1449 - 3rd Edition (E316468)

General Interconnection Diagram

Suitable for use on a circuit capable of delivering not more than 200,000 rms symmetrical amperes, 150 Vrms maximum, when protected by a RK5 Class fuse, or a circuit breaker rated at 50A or less.

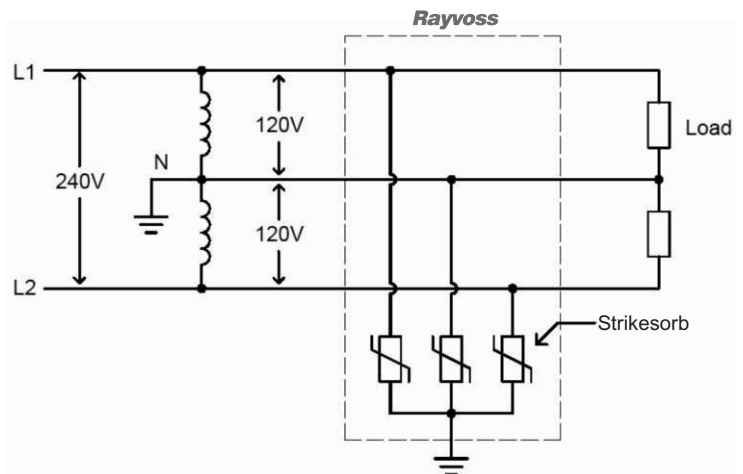

For additional information:

Raycap Inc.
www.raycapinc.com
Toll Free: 800 890 2569



Raycap

04-165-B

Type 2 - Surge Protective Device (SPD)

Mounting

This product should be mounted on a solid, flat surface capable of supporting 15 pounds. The mounting hole locations are shown in the diagram to the right.

Warning: Do not use the mounting lugs to make the safety and protection ground.

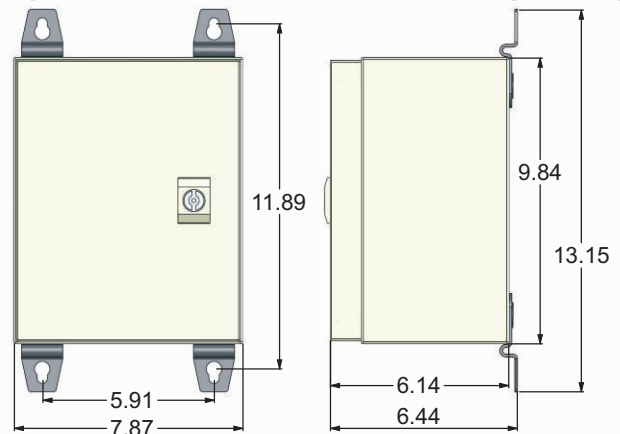

A template to assist with positioning the mounting holes is provided

Connection Methods

This product may be installed in-line or in parallel. The two diagrams below show the different methods.

In-Line Connection

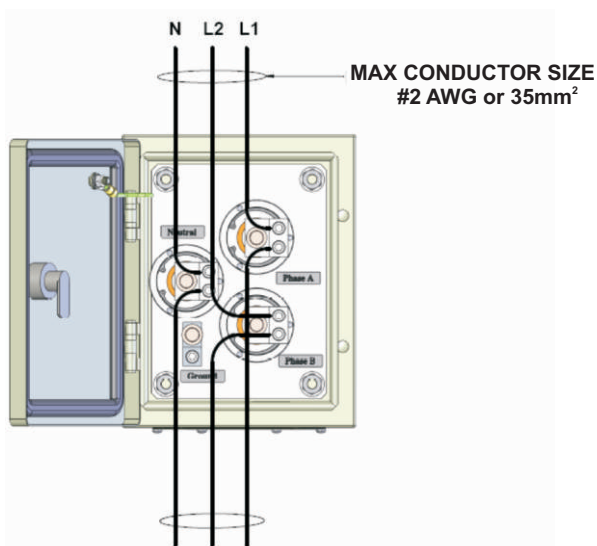

Ground conductor not shown for clarity.

Parallel Connection (T-Connection)

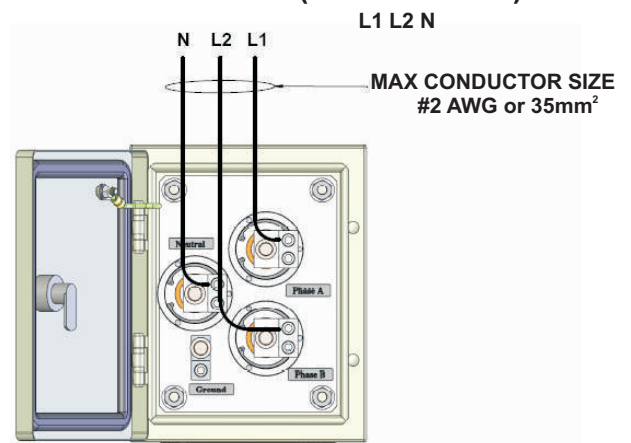

When installing in a T-Connection:

To ensure maximum performance of this product, the installation should use the largest gauge, shortest, and straightest conductors feasible.

Grounding

The ground connection should be made to the ground terminal mounted inside the Rayvoss unit. The connection should be made using a short, straight cable to the power ground or to the main ground bar at the installation location.

For additional information:

Raycap Inc.
www.raycapinc.com
Toll Free: 800 890 2569



04-165-B

Raycap