

Chloride CP Series Parallel Redundant UPS (Three-Phase 10 - 20 kVA): The Chloride CP Series UPS is designed for high-end industrial, datacom, and commercial users who demand the best performance and maximum reliability from their electronic systems. Field-upgradable technology allows for easy scalable power and runtime upgrades as well as N+1 distributed or centralized paralleling on your premise.

True on-line, double conversion technology

The CP Series UPS is a true "on-line," double conversion, pulse width modulated (PWM), three-phase output UPS that employs the latest in high-speed switching Isolated Gate Bipolar Transistor (IGBT) technology.

The double conversion design provides the highest degree of critical load isolation from damaging commercial power aberrations.

Parallel redundant

The CP Series UPS is designed to parallel (up to 8 UPS modules) for redundancy and/or capacity while providing 24/7 availability for mission-critical systems. The results? Increased availability, reliability, and operating efficiency.

Superior reliability

The CP Series offers critical load protection and, with the variety of options available, can be configured to meet specific needs. The CP Series is easy to install, operate and maintain.

Options

- MopUPS® Professional Software
- ManageUPS®_{NET} SNMP, WEB, and Telnet Adapter
- SNMP-based UPS monitoring
- 10% Input Harmonic Filter
- Remote Alarm Unit
- Parallel Kit
- External Maintenance Bypass with optional Kirk Key Systems or Solenoid Key Release
- Extended Battery Runtime
- Field Upgrades
- Spare Parts Kits

Service

- Start-Up & Commissioning
- Extended Warranty Programs
- Preventative Maintenance Programs
- Battery Programs
- LIFE2000: 24-hour remote monitoring and diagnostics



- True On-Line Double Conversion Design
- Parallel Redundant (up to 160 kVA are available by paralleling up to 8 modules)
- IGBT PWM Inverter
- Power Factor Corrected Input
- Internal Maintenance Bypass As Standard
- Field-Upgradable for On-Site Flexibility
- Dual or Single Input Available
- User-Friendly Display
- Low Output Distortion Even with Non-Linear Loads
- State-of-the-Art Communications Solutions
- Advanced Battery Management
- Top and Bottom Cable Entry
- Caster Equipped for Ease of Installation
- Built to Meet Stringent UL/cUL 1778 Requirements
- Manufactured under ISO 9001
- Full 1-Year Warranty
- Free 24-Hour Technical Support (800) 388-4234, (847) 990-3229

Chloride CP Series Parallel Redundant UPS: Specifications

Model	10 kVA			15 kVA			20 kVA		
	(2x2)	(4x2)	(4x4)	(2x2)	(4x2)	(4x4)	(2x2)	(4x2)	(4x4)
Part number	CP3020/10-2X2	CP3020/10-4X2	CP3020/10-4X4	CP3020/15-2X2	CP3020/15-4X2	CP3020/15-4X4	CP3020/20-2X2	CP3020/20-4X2	CP3020/20-4X4
kVA/kW @ .8 PF	10/8	10/8	10/8	15/12	15/12	15/12	20/16	20/16	20/16
Input voltage (dual input) - three-phase (single input)	208	NA	480	208	NA	480	208	NA	480
Output voltage - three-phase	208Y/120	208Y/120	480Y/277	208Y/120	208Y/120	480Y/277	208Y/120	208Y/120	480Y/277
Frequency (Hz)	60	60	60	60	60	60	60	60	60
Nominal input current (Amps)	27	12	12	40	17	17	53	23	23
Maximum input current (Amps)	40	17	17	53	23	23	66	29	29
Nominal output current (Amps)	28	28	14	42	42	18	56	56	24
Percent efficiency	86	86	86	87	87	87	87	87	87
Full load heat rejection (BTU/hr.)	4,443	4,443	4,443	6,118	6,118	6,118	8,150	8,150	8,150
Height - inches (cm)	69.0 (175)	69.0 (175)	69.0 (175)	69.0 (175)	69.0 (175)	69.0 (175)	69.0 (175)	69.0 (175)	69.0 (175)
Width - inches (cm)	27.6 (70)	27.6 (70)	27.6 (70)	27.6 (70)	27.6 (70)	27.6 (70)	27.6 (70)	27.6 (70)	27.6 (70)
Depth - inches (cm)	38.6 (98)	38.6 (98)	38.6 (98)	38.6 (98)	38.6 (98)	38.6 (98)	38.6 (98)	38.6 (98)	38.6 (98)
UPS net weight - lbs. (kg.)	850 (386)	850 (386)	850 (386)	850 (386)	850 (386)	850 (386)	850 (386)	850 (386)	850 (386)
UPS shipping weight - lbs. (kg.)	950 (432)	950 (432)	950 (432)	950 (432)	950 (432)	950 (432)	950 (432)	950 (432)	950 (432)

NOTE: Battery life is optimized at 25°C (77°F). For every 8°C (15°F) above optimum temperature, battery life is reduced by 50%. All runtimes are approximate and are based on 1.67 final volts/cell (final volt per cell), 77°F, and 0.8 power factor at end of discharge, unless otherwise noted. Actual runtimes may vary. Runtimes over 60 minutes are based on 1.75 final volts/cell.

Part number	CP-PACK-501	CP-PACK-502	CP-PACK-503	CP-PACK-504	CP-PACK-505
Battery cabinet and type	Internal	G	G	H	H
Dimensions - HxWxD - in (cm)	NA	69x18.3x37 (175x46x94)	69x18.3x37 (175x46x94)	69x27.6x37 (175x70x94)	69x27.6x37 (175x70x94)
Net weight - lbs (kg)	740 (336)	1280 (581)	1700 (771)	2400 (1089)	2400 (1089)
Shipping weight - lbs (kg)	NA	1480 (673)	1900 (864)	2600 (1182)	2600 (1182)
Runtime- 10/15/20 kVA model (min)	40/23/14	63/37/26	103/61/44	138/86/61	153/89/63

One-line diagrams

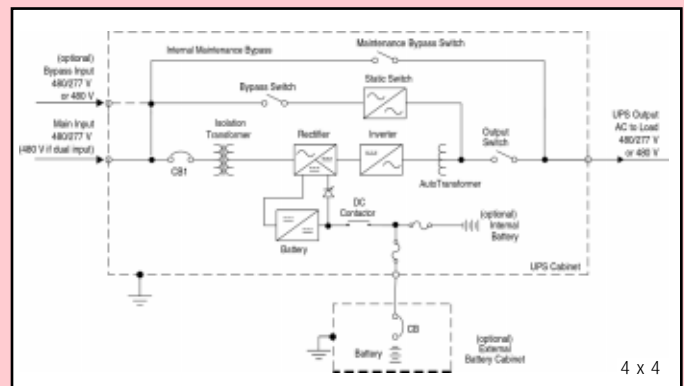
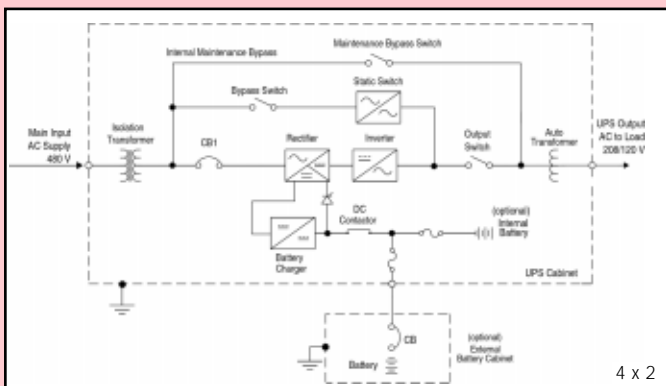
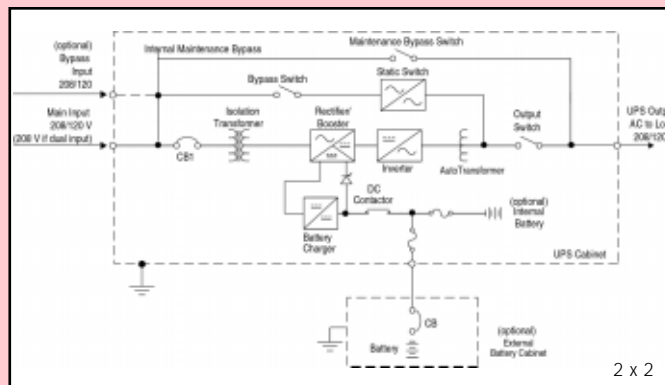

ONEAC, MopUPS, and ManageUPS are all registered trademarks of ONEAC Corporation. All other trademarks are the property of their respective companies.

ONEAC is a UL/BSI registered corporation — Certification No. A2900



A CHLORIDE POWER PROTECTION COMPANY

Pre-Sales (800) 327 8801 OPT. 2 in USA AND CANADA

+44 (0) 2380 610311 in UK AND EUROPE

27944 N. Bradley Road, Libertyville, IL 60048 Post-Sales Phone 847 816-6000 FAX 847 680-5124

George Curl Way, Southampton, Hampshire SO18 2RY, UK FAX +44 (0) 2380 610852