

# MGE™ EPS™ 8000

Three phase UPS

555/625/750/800 kVA



**Performance 3 phase Power Protection with high active power density and adaptability to meet the unique requirements of very large datacenters, buildings and mission critical environment.**

- > Flexible and very adaptable
- > Strong electrical features
- > Intuitive monitoring
- > Parallel capable output
- > Synchronization to external source
- > High availability architecture components

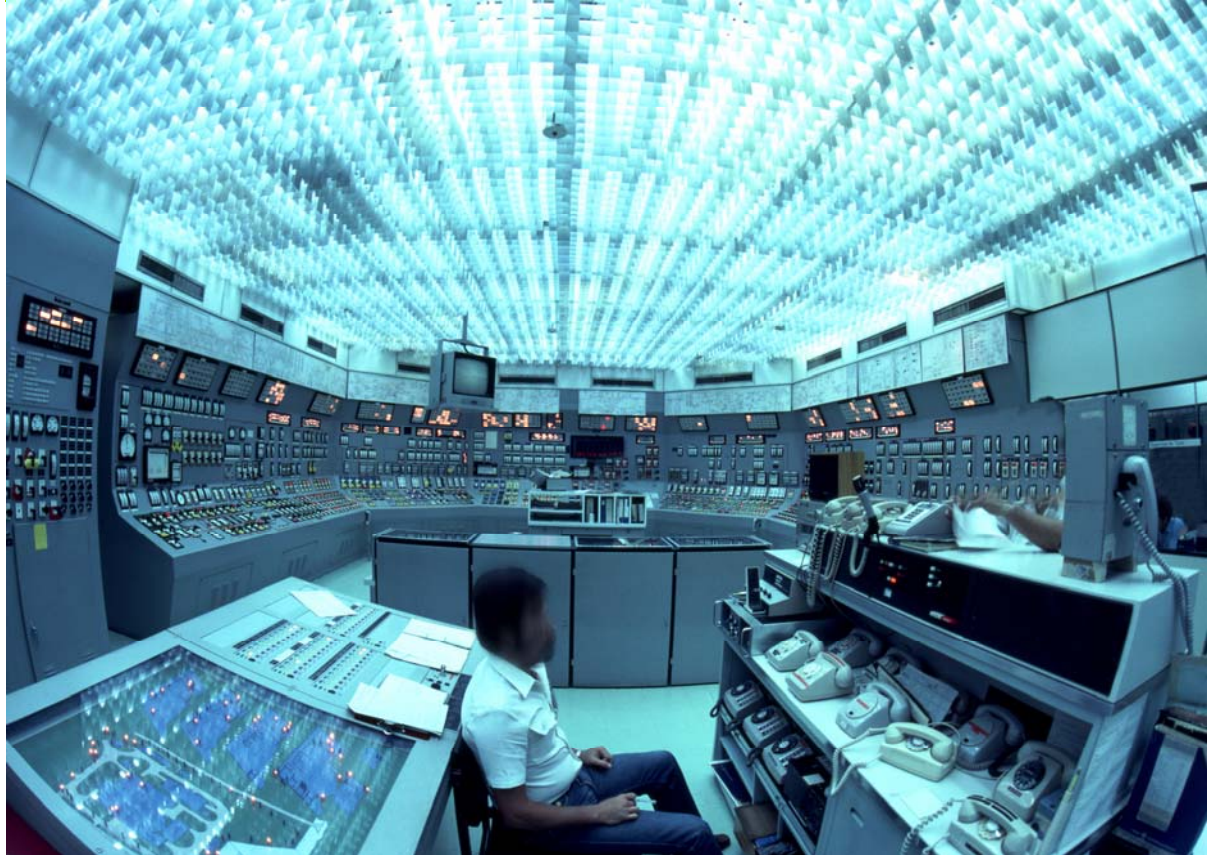

 + APC  
MGE = peace of mind

Customer

# MGE™ EPS™ 8000 Features

## Integrated Input Isolation Transformer

Every MGE™ EPS™ 8000 is equipped with an input isolation transformer fully integrated into the core module. Integrating the transformer directly into the module saves footprint and provides all the benefits of galvanic isolation including providing a very robust buffer between the utility and the critical load.

## 12 Pulse Rectifier

By using a 12 pulse rectifier the MGE™ EPS™ 8000 greatly reduces nominal harmonics reflected onto the utility bus. This means that the input filter required to reduce harmonics down approximately 5% is only a fraction of the size of a traditional six pulse UPS module.

## Graphical User Interface:

The Advanced Graphical Interface for the MGE™ EPS™ 8000 UPS system features a 12" high contrast TFT LCD touch screen. Delivering features including animated mimic diagrams, alarm event logs, trending, component level status and more, the interface presents UPS status information in an easy to read graphical format. Guided by a clear menu, users can navigate through all screens to explore system level information on multi-module systems drilling right down to module and component level information. Operator procedures simplify the use of the UPS, contributing to an overall increase in reliability by mitigating user errors.

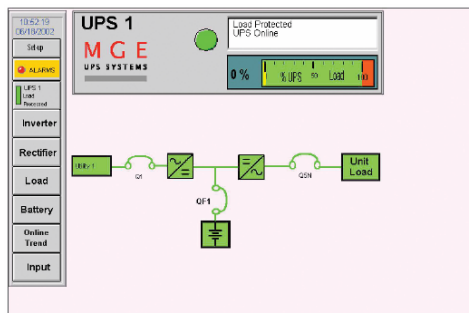

## 100% step load response– The Essential Performance Characteristic

Another feature of MGE's Digital Power Quality Management technology is the inverters super dynamic response. Even in the event of a 100% step load (0% load to 100% load instantly placed on the output of the UPS) the output voltage will still remain in tolerance for all three phases. Even when facing step load changes as high 100% of the nominal load, the MGE™ EPS™ 8000 inverter maintains output voltage regulation to within 5% or better on all phases.

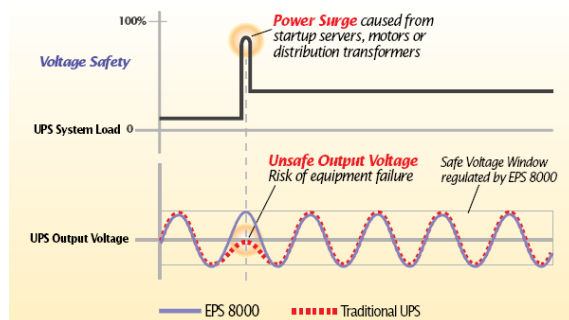

This regulated dynamic response is essential as extreme step loads are common when starting distribution transformers or large banks of servers. Medical imaging systems and broadcast transmitters also exhibit very high step loads making the MGE™ EPS™ 8000 ideal for such applications.

Good dynamic response is also vital in redundant UPS systems when the redundant UPS is required to pick up 100% of the load in the event of a power transfer from the primary UPS. The redundant UPS must be capable of instantly sustaining any load level without any decay in voltage quality. While many manufacturers publish equivalent specifications stating that their UPSs are capable of sustaining 100% step loads (0-100% load) with a maximum of 5% change in the output voltage, it is advisable to confirm these results in a test bay, as variations to this specification have been very common. Any noticeable voltage deviation during a step load will compromise the system reliability, which may in turn compromise the critical load.



# MGE™ EPS™ 8000 Features

## Digital Power Quality Inverter

The most outstanding feature of the MGE™ EPST™ 8000 is the digital inverter. Using a unique technology called Digital Power Quality Management (DPQM), the inverter maintains precision voltage regulation under all operating conditions. The key to the superior performance lies in the speed and resolution of the waveform which is generated by up to eight pulses per millisecond allowing the waveform to be tightly controlled. The waveform is constantly compared to a real time reference sine wave. If the sine wave deviates from the reference sine wave, the gain of the inverter output is adjusted creating a "correction" pulse maintaining a "power quality envelope" that is  $\pm 1\%$  of a perfect sine wave. A free switching frequency accelerates during periods of major variations for better regulation. By optimizing the switching frequency, the MGE™ EPST™ 8000 is also able to minimize switching losses and maintain a high efficiency level even at lower loads.

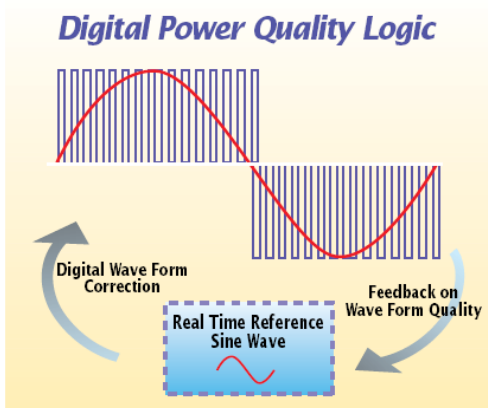

Another benefit of the high-resolution control topology is that harmonic distortion reflected from the loads is practically eliminated. The error correction pulses counteract the reflected waveform distortion reducing THD to under 4%.

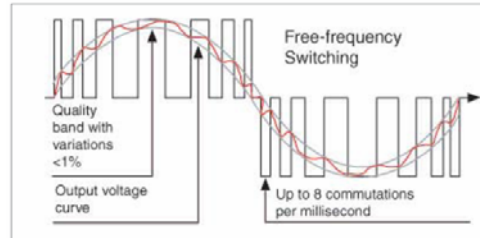

Some other UPS manufacturers claim they have PWM inverters but have simply continued to use their old SCR based inverter designs and substituted IGBT's (Insulated Gate Bipolar Transistors) into the circuit where the SCR once was used. Since these designs still switch the transistors at 60 Hz (very slow) they effectively produce a step wave and have no active sub cycle filtering capability to combat reflected harmonics and can not respond quickly to dynamic (i.e step) loads. To convert the step wave output to a sine wave the inverter output needs to be put through extensive filtering system before it can appear as a sine wave. Even after filtering, this technology still leave remnants of a step wave visible on a scope trace. The dependency on the inverter trap filtering also reduces reliability, as it is another failure risk added to the circuit.

## Accessibility

**Power Density:** The MGE™ EPST™ 8000 has the highest power density (footprint to kW) of any UPS in its class providing up to 720 kW at 0.9 power factor and up to 23 kW / square foot power density. This is over 12% more power than competing standard models. As average loads are growing annually (average IT and computer loads are increasing by 15% annually) the extra power provided by the MGE™ EPST™ 8000 will easily accommodate future growth, realizing significant savings by avoiding the requirement for future system upgrades.

Among the only UPS with 100% true front access, the MGE™ EPST™ 8000 requires no rear or side access. All electromechanical connections are accessible via the front of the unit. All UPS systems require access to all major connections and components for visual inspection, thermal scanning and torquing operation or, in many cases, to satisfy insurance requirements. The MGE™ EPST™ 8000 mechanical configuration facilitates these requirements thus improving reliability and saving valuable footprint.



# MGE™ EPS™ 8000 Features

## Solid State Static Transfer Switch

When a UPS system experiences an overload condition that the inverter can not handle, it immediately transfers to utility power via the static transfer switch, allowing the utility to maintain the overload. Ideally the static transfer switch should be a 100% solid state assembly (consisting of two reverse biases SCRs). Some manufacturers have opted to use mechanical contractors in parallel with fast acting SCR static transfer switches. This hybrid technology allows the use of smaller, lower current, lower cost, partial duty static transfer switches to perform the fast switching from inverter to utility in the event of an overload condition, while the mechanical contactor activates to sustain the current in the long term. Unfortunately this technology is not well suited to sustain very high overload currents (i.e., 200% to 300% +) which may cause severe arcing and even contactor failure. Also, since the contactor is a mechanical device, its probability of failure is higher than that of 100% solid state static switch assembly.

## Demonstrated Reliability as the Industry's Best UPS

Reliability can be expressed on paper with mathematical equations and even via standards such as MIL-217. Mathematical methods of expressing reliability are subject to the methodology, with even well recognized standards with defined methodologies differing from calculation to calculation and subject to creative interpretation. In fact, when comparing most major manufacturers reliability according to MIL-217, the results are very close. MGE prefers to measure the reliability of the MGE™ EPST™ 8000 by looking at our customers and more importantly the number of customers who continue to buy our systems. MGE™ EPST™ 8000 customers include the world's largest Internet providers, semi-conductor manufacturers, insurance and financial institutions and telecommunications companies. Many of these customers have the potential to lose more on single outage than the cost of the UPS making reliability the primary factor in selecting a UPS. Even after exhaustive independent consultant engineer investigations among all major UPS manufacturers, the MGE™ EPST™ 8000 has time and again proven to be the most reliable solution on the market. Furthermore, MGE has now supplied many of these same customers for the third time with the MGE™ EPST™ 8000 family.



Large disc SCRs used on the static bypass of the EPS 8000 allow the UPS to clear huge fault currents with ease.



## Fault Tolerant Output

It's highly probable that sometime over the life of the UPS system, it will experience a dead short or fault on the output bus. In fact, applications such as TV transmitters frequently exhibit dead short characteristics as a normal part of their operation. Even if the short occurs downstream of low current circuit breakers, the UPS may have to endure up to six cycles of the fault before the circuit breaker trips. The probability of such an event makes it imperative that the UPS be able to sustain a dead short without damage, and automatically return to normal operation once the fault has cleared.

The MGE™ EPST™ 8000 again relies on the Digital Power Quality Management Technology to manage dead shorts without compromising the UPS. Because of the ultra fast sensing technology and high switching resolution, the inverter is able to sense a fault in microseconds and seamlessly transfer the load to utility power via the 100% rated, continuous duty static transfer switch that has enough capacity to clear virtually all upstream faults. Once the fault has cleared, the UPS will return to inverter operation. This fault tolerant technology is an essential advantage of the MGE system, adding reliability to one of the most vulnerable parts of the UPS.

Many other UPS do not have the ability to shut the inverter down fast enough once a fault is present. The result is that they continue to pump energy through the IGBTs, exceeding their thermal tolerance and destroying the inverter requiring costly repair and potentially dropping the load.

This fault tolerant technology is an essential advantage of the MGE system, adding reliability to one of the most vulnerable parts of the UPS.

**APC**®

by Schneider Electric

# Specific Technical Advantage

## Energy Efficient for Significant Cost Savings

The energy efficiency of the MGE™ EPST™ 8000 is extremely high especially at lower loads where redundant UPSs operate. Even with the standard input isolation transformer (most published efficiencies do not include the input isolation transformer), efficiency is among the highest in the industry. The result is often energy cost savings that usually exceed the cost of the UPS module in as little as three to five years compared to leading brands. This efficiency advantage is due to MGE's Digital Power Quality Management technology that optimizes the output waveform to match the load profile, minimizing wasteful switching losses.

- > Core efficiency as high as 94.5% and 93% with input isolation transformer
- > High efficiency maintained over lower load levels where most UPSs operate
- > Potential energy cost savings that can equal the value of the UPS in as little as a few years

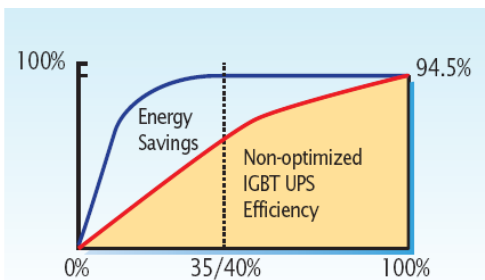

MGE™ EPST™ 8000 features a high efficiency rate that remains stable even at lower loads where most UPSs operate. The energy cost savings usually exceeds the value of the UPS in as little as three to five years. The efficiency shown above is the core efficiency without the input isolation transformer for comparison purposes.



## Generator Compatibility/Input Filter Technology

The MGE™ EPST™ 8000 is the most generator friendly UPS thanks to its unique input filter technology. This technology eliminates one of the major reliability risks associated with large UPS systems- the failure of the generator to support the UPS under low load conditions. The 1 to 1 sizing ratio of the MGE™ EPST™ 8000 allows for significant cost saving by eliminating the need for generator over sizing.

Generator/UPS interaction problems are typically caused from the capacitors located in the input filter (used to regulate the THD reflected by the UPS rectifier) which create very high reactive currents at loads below 40% (where most UPSs operate). Most generators are not able to tolerate these reactive currents (high leading power factors) as they disturb the generator's voltage regulation circuit causing the generator to lose regulation and potentially go off-line.

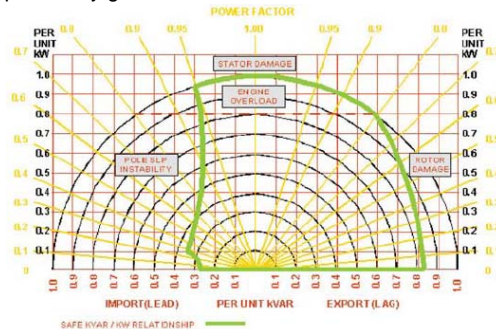

The traditional way to combat the problem of the UPSs reactive currents is to grossly oversize the generator by up to three times in the case of multi-module systems. This is an extremely expensive solution that also requires that the generator operate at very low loads—causing carbon build up and shortening the life of the generator. MGE's shunt inductor input filter technology provides a superior solution that both limits input THD and ensures that the input power factor never goes leading – at all load levels. This is achieved by using a passive shunt inductor to balance the power factor. The technology uses highly reliable passive components and does not involve any mechanical switching. The result is a very reliable filter technology that permits safe UPS/generator operation without excessive generator over sizing.



# The most comprehensive range of services

## Solid State Technology

MGE's design uses only 100% solid state technology with no calibration or potential drift occurring on any part of the system over the life of the UPS. By avoiding the use of trim potentiometers and other calibration sensitive devices, the UPS can perform accurate self-diagnostics immediately alerting users to any anomalies. The 100% solid state self calibrating design also allows Field Engineers to analyze the complete operation of the UPS in minutes simply by plugging a PC into the UPS's diagnostics port.

This avoids costly maintenance inspections, and ensures that no part of the UPS is left un-inspected. Some other UPSs are heavily reliant on trim potentiometers that are by nature subject to drift and require extensive calibration.

## Maintenance contracts

UPSs must be managed and monitored to keep them in optimum working order. Schneider Electric Critical Power and Cooling Services offers three levels of maintenance contracts:

- ULTRA, total service, all-inclusive, peace of mind guaranteed
- PREMIER, for effective basic preventive maintenance
- SELECT, For a moderate level of coverage, Select Service offers a discount on parts and labor associated with corrective maintenance, 30-minutes maximum callback time, and next business day or sooner on-site arrival time. Parts, labor and travel expenses associated with corrective maintenance are billed separately at discounted time and material rates.



## Commissioning

Schneider Electric Critical Power and Cooling Services provides commissioning service for all new equipment with support to meet your specific requirements.

## Managing an installation calls for Upgradeability

To be sure of benefiting from the management of an installation, Schneider Electric Critical Power and Cooling Services provides solutions for upgrading:

- Technical upgrading
- Upgrading battery functions
- Site audits, studies and analysis of the UPS environment
- Harmonic audits

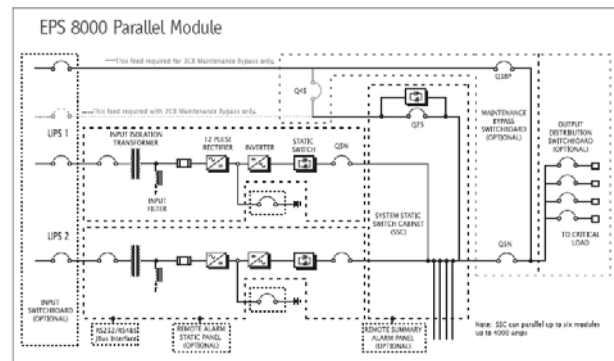
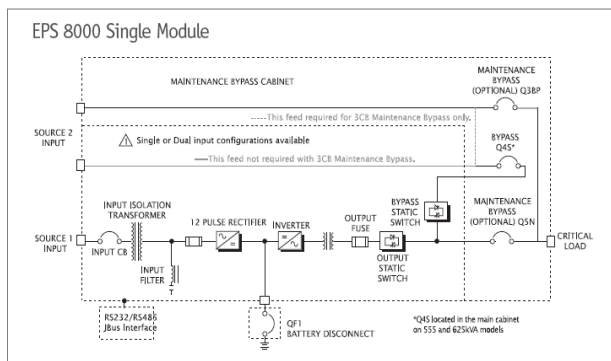

# Technical characteristics

Rated power (kVA / kW)	555/500	625/562	750/675	800/720	555/500	625/562
<b>Normal AC Input</b>						
Input Voltage (V)	480 (3ph,3/4 W + GRD)			600 (3ph,3/4 W + GRD)		
Frequency (Hz)	60 Hz + 10%					
Power Factor	0.9 lagging , 0.95 with filter 4 kVAR max leading					
Distortion	5% max. THD at full load					
Nominal Input Current (A)	719	817	1,034	1,103	575	654
Maximum Input Current (A)	825	923	1,126	1,195	663	741
<b>Bypass AC input</b>						
Voltage (V)	+10/-15 % UPS output (3ph,3/4 W + GRD)					
Frequency (Hz)	60 Hz (+0.25 Hz up to 2 Hz)					
Input CB (kAIC)	100			65		
Input CB: Trip (A)	1,200		1,600		1,000	
Input CB : Frame Size (A)	2000					
Normal Bypass Current (A)	668	752	900	960	534	601
Maintenance Bypass CB <sup>2</sup> (kAIC)	65					
Maintenance Bypass CB Frame size (A)	1,000		1,200		800	
Maintenance Bypass CB Trip (A)	1200					
<b>Output</b>						
Power Factor	0.9					
Output Voltage (V)	480 (3ph,3/4 W + GRD)			600 (3ph,3/4 W + GRD)		
Frequency (Hz)	60 Hz (selectable +5%) 0.1% free running					
Voltage Regulation	+/- 0.5% steady state (+2.5% 100% step load)					
Voltage Distortion	4% max. for non-linear loads w/crest factor of 3.5 2% max. linear load					
Inverter Overload	125% for 10 minutes, 150% for 1 minute					
UPS Output isolation CB <sup>2</sup> (kAIC)	65			25		
UPS Output isolation CB Frame size (A)	1,000		1,200		800	
UPS Output isolation CB Trip (A)	1200					
Max Output Current (A)	668	752	900	960	534	601
<b>Battery</b>						
Max DC Current (A)	1,364	1,533	1,766	1,884	1,364	1,533
DC Breaker Trip Size (A)	1,600		2,000		1,600	
DC Breaker Frame Size (A)	2,000					
<b>Overall efficiency</b>						
System efficiency	93%					
Full Load Heat rejection (BTUs)	125,970	133,300	173,000	190,000	125,970	133,300
<b>Environmental conditions</b>						
Operating Temperature	0°C to 40°C (32°F to 104°F)					
Non-Operating	-20°C to +45°C (-4°F to 113°F)					
Audible Noise	75 dB 5'					
Relative Humidity	0-90% non condensing					
<b>Dimensions and Weights</b>						
Multi Module (W x H x D)	121" x 82" x 39"					
Single Module-Top entry (W x H x D)	121" x 82" x 39"		135" x 82" x 39"		121" x 82" x 39"	
UPS Cabinet (lbs)	12,200		14,000		12,200	
Maintenance Bypass for single module (W x H x D)	22" x 82" x 39"					
Bottom Entry (W x H x D)	36" x 82" x 39"					
Battery Disconnect (W x H x D)	36" x 82" x 39"					
Max. Shipping Split (W x H x D)	61" x 82" x 39"					

