

BTMFactstar 2

Battery Monitoring System

The Factstar™ series of battery monitors offer advanced monitoring and alarming capabilities at a fraction of the cost of other monitoring systems.

Factstar™ uses float current measurements in conjunction with measurements of battery segment voltages to provide a clear indication of battery health and alert personnel of impending battery problems well in advance of battery failure.



Detection and measurement of:

- Impending Thermal Runaway
- Common Charger Malfunctions
- Aging Battery Conditions
- Shorted Battery Cells
- Open Battery String
- High Temperature
- Insufficient Cooling
- High AC Ripple
- Battery Segment Voltages
- Segment Internal Resistance
- Discharge/Charge Profiles

The high sampling speed and low cost of the system make it ideally suited for monitoring batteries used in **Telco** and **Diesel Generator** applications.

Factstar™ is designed with simplicity in mind. The system can be installed in minutes. Simple alarms indicate whether the battery is good, bad or in need of service while the system collects and stores battery data that can be analyzed using our BTM Global software or imported into standard spreadsheet or database applications.

Float current, the current present when the battery is in a floating condition, will change very predictably under most common conditions that lead to battery failure. Battery segment voltages provide additional information on the battery health and age.

The system can be used as a standalone device or integrated into an existing facilities management system. It is compatible with Polytronics BTM Global system which will allow monitoring of thousands of distinct sites from a centralized location.

The system can be used in conjunction with the BTM 4000 series of monitors, allowing measurement of individual cell parameters.



Polytronics Engineering Ltd.

Toll Free: 877.355.5550
www.polytronicseng.com

BTMFactstar 2

Battery Monitoring System

Accurate Float Current measurements are obtained, using a unique saturation technique, developed by Polytronics Engineering. This technique yields floating current measurements with resolution of one milli-ampere, even in presence of High AC ripple current. The Factstar™ is also capable of measuring discharge and charge currents of up to 1000A without the need of additional sensors.

The Factstar™ Battery Monitor can be configured to store up to 4096 records (approx. 1 year of data), allowing detailed analysis of the battery voltage, current, AC ripple and internal resistance trends and early detection battery deficiencies. This data can be downloaded and stored for archival purposes.

Factstar™ generates alarms for open strings, increased ripple current, pending loss of load during discharge, segment voltage abnormalities and pending thermal runaway. Alarms are generated locally (through a contact closure) and remotely via a modem or Ethernet connection (ASCII text).

The Factstar™ requires no shunt and if a split core is used can be installed without disruption of the string. The user is able to view the real time measurements of the current on the optional LCD, or download the content of the memory in CSV format.

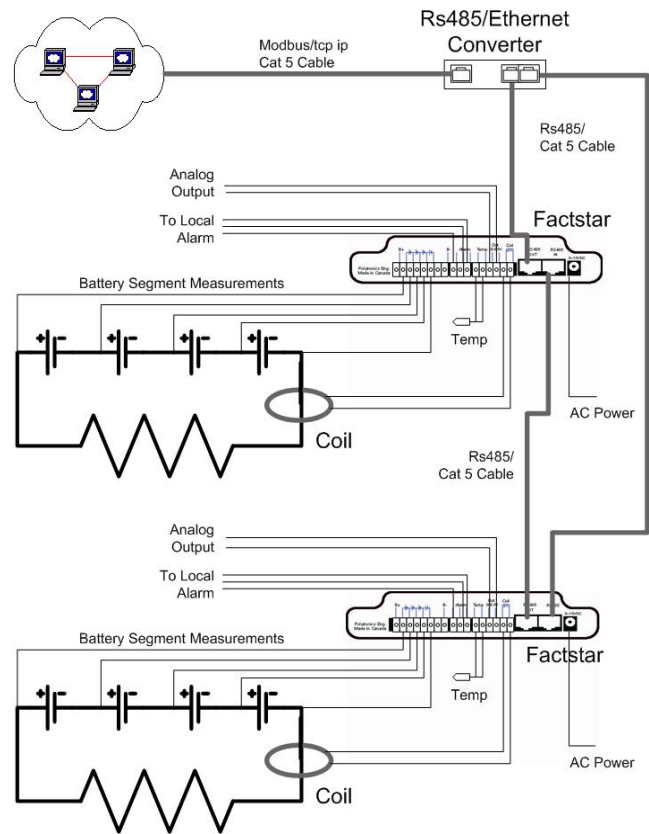

TECHNICAL SPECIFICATIONS	
Supply	15 - 24 V DC (Battery Backup Option Available)
Power Source	AC Adapter or battery being monitored
Analog Output	0 - 50 mV / 0 - 5V (optional)
Digital Output	RS232/RS485 and fiber optical ports
Operation Range	Current: 0 - 1000A DC Voltage 0 – 600VDC
Alarm Conditions	High float current, temperature out of limits, high AC ripple, Open string, string exhausted, and segment voltage abnormalities.
Sampling speed	200 milliseconds
Averaging	Configurable
Size	5.625" X 3.5" X 1.25"
Resolution	1 mA @ < 8 A AC, 0A DC 0.3V @ 600VDC per segment
Records and stores AH, Float, Charge, Discharge and Ripple current (rms and peak), segment voltages. History files are available over series port or optional Ethernet module. Can withstand thousands of amperes of current	