

CM Technology

- 380V – Medium Voltage Input
- Batteryless System
- 12 Second Ride-Through
- Low Speed Flywheel Based System
- Frequency Injected System
- >96% Efficiency at Full Load
- Ability to convert to a full Rotary UPS Systems by electrically coupling to an Engine Generator
- Manufactured in the USA

US – RUPS Rotary Ride Through 2200kVA



US-RUPS - 2200 RRT

CM Technology's US-RUPS advance rotary ride through power supply is designed to provide 12 seconds of batteryless ride-through for power line sags, swells and outages. The 2200 RRT has an operating voltage range between 380V and 15.0kV.

The US-RUPS Rotary Ride Through is comprised of an induction motor/generator with a surge-limiting line reactor, electronic control package and a low speed (1800 rpm) steel flywheel. This system can be electrically coupled to a generator with long-term stand by power which creates a 2200kVA Rotary Uninterruptible Power Supply (UPS System). The RRT System is also equipped with the necessary switchgear for connection to the utility feeder.

In normal operation, the electronic power controller (EPC) operates the IMG as a motor to control the speed of the flywheel to

a nominal 1800 rpms. The EPC adjusts the operational characters of the IMG to improve the quality of the power supplied from the grid by compensating for voltage deviations and sub-cycle power anomalies. This is accomplished by injecting a synthesized current into the rotor of the IMG and using the impedance of the IMG inductor to isolate grid disturbances.

When utility power deviates from tight voltage or frequency tolerances, the flywheel/IMG combine to operate as a generator to provide complete uninterrupted power to the load. If the out-of-tolerance condition on the grid persists for longer than a pre-programmed time (typically 2 seconds), the stored energy in the flywheel provides sufficient ride-through until an optional engine generator comes up to speed and replaces the RRT as the primary power source to the load.

For more options or assistance contact CM Technology with your application needs
Phone (978) 664-6218 • Fax (978) 664-6219 • E-mail sales@us-rups.com

The US-RUPS RRT-2200 System is designed to provide conditioned and continuous power within tight tolerances during failure or deterioration of the normal power supply in commercial, critical process, industrial, medical and a variety of other power quality and reliability applications.

As shown in figures 1 and 2, the main components of the RRT-2200 system include a steel flywheel which is connected to an induction motor/generator (IMG) by a coupling, a bi-directional converter, breakers, monitoring and power electronic control modules. The converter, breakers and power electronic control modules can be packaged in a separate enclosure and be installed at a remote location. This system can also be electrically connected to an optional engine/generator system to make a full Rotary Uninterruptible Power System (RUPS).

The innovative design approach used in the RRT-2200 allows for a single wound rotor induction motor/generator replacing the dual electrical machine approach and avoids the need for full power rectifier/inverter conversion in the main power path. The modularized design allows for greater flexibility in the installation of the system that is also compatible with the "Smart Grid" concept. Smart Grid does not replace the national grid but allows for digital communication with the grid for reliable and efficient power distribution to the load. US-RUPS system incorporates this digital communication link which constantly monitors the grid allowing the RRT to compensate for abnormalities in the grid which allows for a more efficient distribution of power at the load without any additional costs. US-RUPS RRT 2200 System is not only an innovative design but has also been engineered to meet the ever changing and increasing demand of tomorrow's national grid.

US-RUPS - 2200 RRT

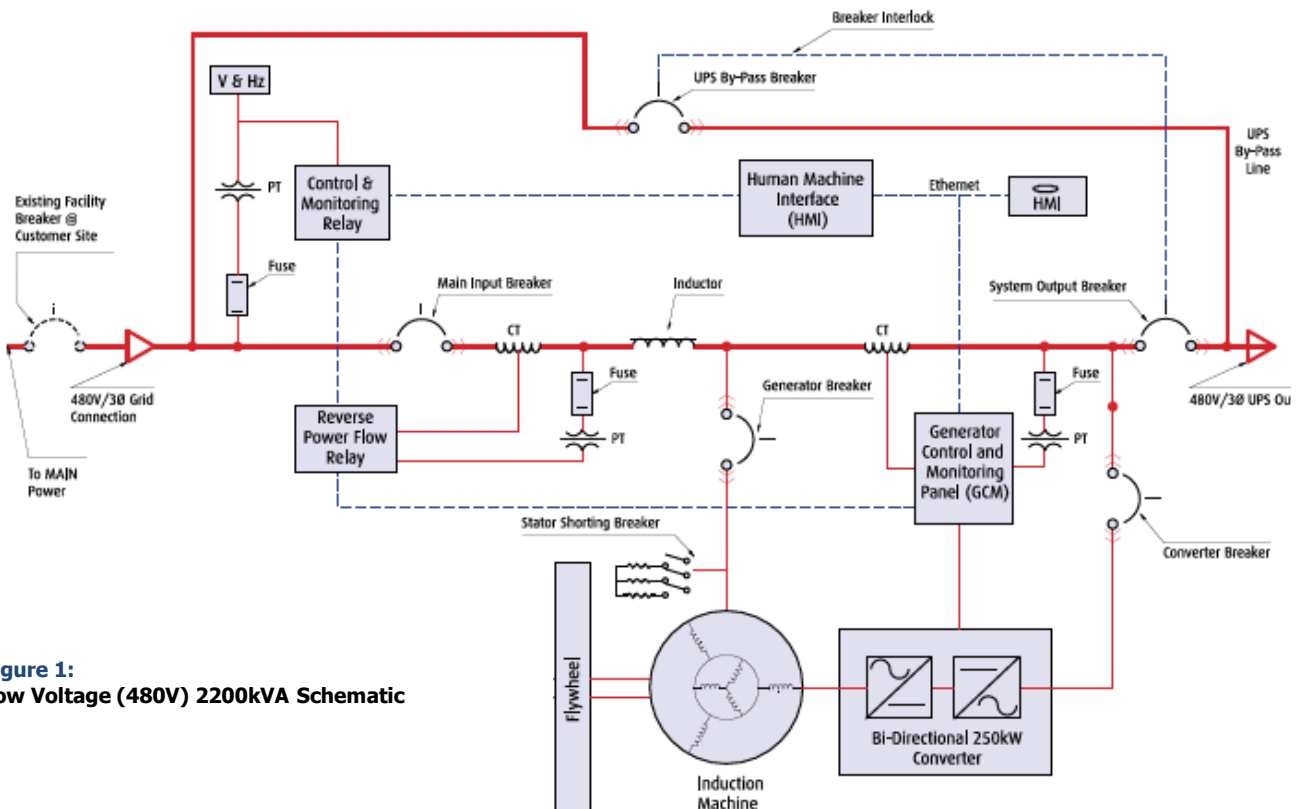

Figure 1:
Low Voltage (480V) 2200kVA Schematic

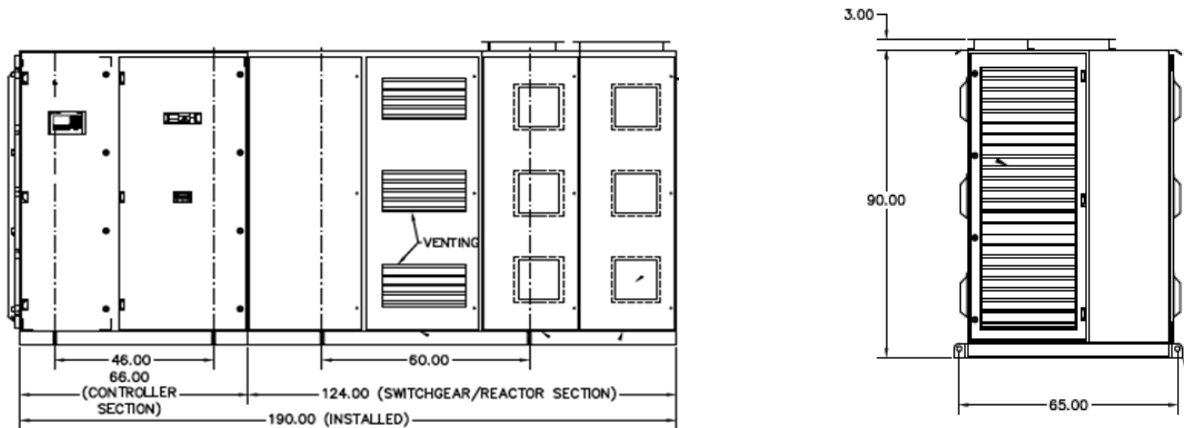
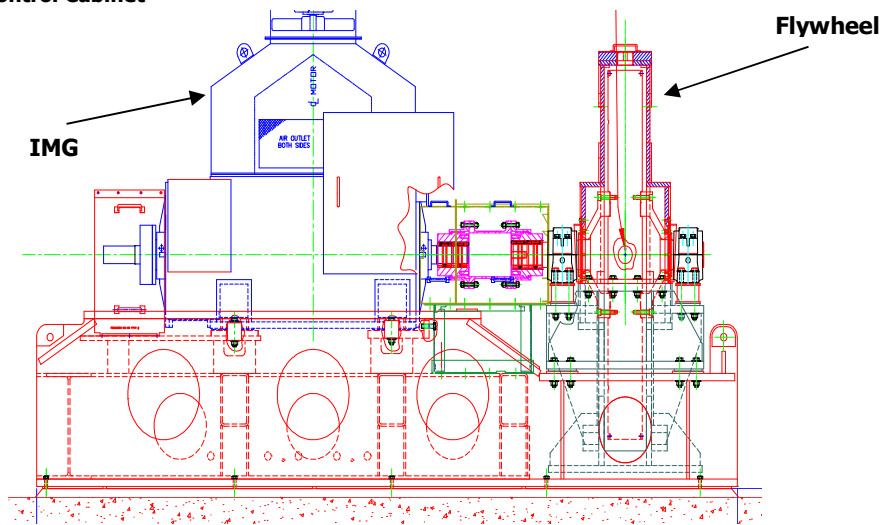

Figure 2:
US-RUPS RRT 2200 & Control Cabinet



US-RUPS - 2200 RRT

Flywheel – Based

Constructed from solid 4340 grade steel, the slow speed flywheel operates at 1980 rpm to provide stored kinetic energy ride-through requirements to mitigate short term utility anomalies such as sags, spikes, surges, brown-outs, brief power outages, etc.

12 – Second Ride Through

Using a vector-controlled frequency injected technology from the bi-directional inverter, the flywheel keeps the generator energized for 12 seconds at full load, providing ride through for short term anomalies in the grid. Should complete power back up be required an optional engine generator can be electrically coupled to the system turning the system into a RUPS. The RRT will send signal to the engine/generator to start and to turn off after the grid has stabilized or at preset time duration.

Flexibility

System can be configured to run as a UPS System with the addition of an engine/generator, for low to medium voltage with the addition of a step down transformer, can be packaged to fit within an ISO sized container, can provide either AC or DC output power, multiple RRT's can be run in parallel to increase capacity, additional flywheel wheel can be added to increase ride through time.

Customization

The US-RUPS 2200RRT System has been designed to accommodate a wide array of custom requirements. Please contact our sales department to discuss your specific needs at (978) 664-6218 or e-mail us at sales@us-rups.com

US-RUPS Rotary Ride Through

SPECIFICATIONS

GENERAL SPECIFICATIONS

Temperature Range	
Operating	+5 to +40°C
Non-Operating	-20 to +80°C
Relative Humidity	0-95%/o, Non-Condensing
Altitude	0-3000' (0-914m) Without De-rating
Audible Noise	95dBa Max. at 3' (0.91m)

MECHANICAL SPECIFICATIONS

Flywheel/IMG (2200kVA unit)	
Dimensions (W x H x D)	16' x 11.5' x 8' (4.8m x 3.5m x 2.4m)
Weight	39,000 Lbs. (17,728kg)
Control Cabinet	
Dimensions (W x H x D)	175" x 90" x 60" (445cm x 229cm x 152cm)

OPTIONS

- Rotary UPS available by means of electrically coupled engine/generator
- Medium Voltage available by means of step down transformer
- Dual Flywheel and System Paralling for Increased Energy Storage
- Out Put Power DC
- Outdoor (weatherproof) Enclosure Noise-Attenuating Enclosure Remote Monitoring
- ISO Container Packaging
- Full Service Agreements

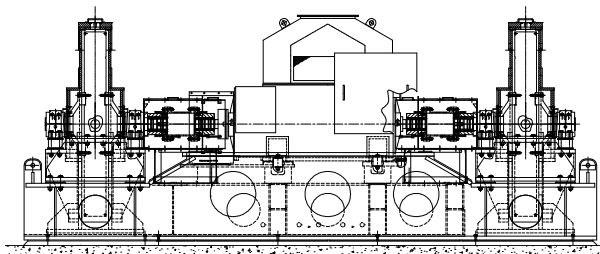
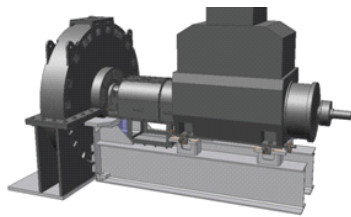

SYSTEM SPECIFICATIONS

Power Rating	2200kVA @ 0.80 pf. / 1760kW
Nominal Input Voltage	380V – 15.0kV, ±10%/o
Input Frequency	60Hz, +0.4/-0.3 Hz
Connection	3 phase, 3 wire + ground, optional 4 wire + ground
Input Power Factor	1.0 to 0.95 Inductive
Efficiency at Rated Load	> 96%/o
UPS to Input Short	
Circuit Current	200%/o for Less Than 100ms
Voltage and Phase Balance	
Unbalanced Loads	±2%/o Phase Voltage; ±2%/o Phase Displacement for Up to 20%/o Unbalanced Load
Balanced Loads	±1%/o Phase Displacement
Output Voltage	Same as Input Voltage; ±1%/o
Output Frequency	<±1.0%/o Upon Loss or Return of Input Voltage
Ride-through	12 Seconds @ Full Rated Load (1760kW)
Output Voltage Distortion	≤ 5%/o for Linear Loads (< 3%/o for any Single Harmonic)
Overload Capability	150%/o for 1 Minute 125%/o for 5 Minutes 110%/o for 1 Hour (10%/o Duty Cycle)
Transient Condition Ratings	
Output Voltage Regulation	+5/-6%/o of Nominal for 50ms
Frequency Regulation	≤ ±1%/o
Frequency Rate of Change	0.5Hz per Second
UPS Mode	
Output Voltage	±1%/o of Nominal
Output Frequency	60Hz ±0.1 Hz
Peak Inrush Current	No inrush for 1MG flywheel / Generator starting, Includes a VFD type Soft Start Step-up Transformer inrush limited to 200%
Harmonic Currents (TDD)	Less than 3% for Linear Load Less than 5% for 100% Non-Linear Load
Power Factor (pf)	Unity to 0.95 at rated load, nominal voltage, for unity to 0.8 Load pf.

**For more options or assistance contact CM Technology with your application needs
Phone (978) 664-6218 • Fax (978) 664-6219 • E-mail sales@us-rups.com**